

PS.X2 PRECISION BALANCES



release date 02-01-2017



PS 200/2000.X2 - PS 1000.X2



PS 1200.X2 - PS 6001.X2



PS 6100.X2 - PS 10100.X2

The **PS.X2 series** represents a **new advanced level** for precision balances.

The X2 series balances feature the latest generation capacitive display providing the maximum comfort of use, available right at your fingertips. Ease of operation, clear menu and practical arrangement of the display guarantee the best ergonomics for your everyday tasks. A wide array of available interfaces facilitate selection of the most optimal means for communication. The X2 series balances offer unlimited possibilities for cooperation with external devices, providing printing, copying, archiving and data transfer. Built-in IR sensors allow numerous operations (e.g. tarring, transmitting the result to a printer or selecting successive steps of a particular process, etc.) to be performed hands-free, by simply moving a hand across the sensor. The housing is made of plastic, and the pan is made of stainless steel.

The balances feature under-pan weighing option - the weighed load is suspended under the balance.

DATABASES IN X2 SERIES BALANCES

In new PS.X2 series balances the information system is based on 7 databases, which allows for several users to work with several products databases, and the registered weighing results can be subject to further analysis.

The data is registered in 7 databases:

- Users (up to 100 users),
- Products (up to 5 000 products),
- Weighments (up to 50 000 weighments),
- Packaging (up to 100 packaging types),
- Formulas (up to 100 formulas),
- Clients (up to 100 clients),
- ALIBI memory (up to 500 000 weighments).

The X2 series features option of making reports of 2 different categories:

- Reports on formulas (up to 200 reports),
- Reports on density determination (up to 500 reports).



High capacity balances featuring new solution for fixing of the weighing pan

The new PS.X2 high capacity balances (6100, 8100 and 10100) feature centrally fixed weighing pan and additional sealing ring. This solution improves air-tightness and simplifies cleaning.

To advance accuracy, the new balances have been equipped with metal anti-draft shield.

Additional assets are both expanded capacity (even up to 10.1 kg) and smaller dispersion of weighings – better repeatability.

Personalization taken to the next level

The X2 is the only balance available on the market that provides a user with the option to design display using wide selection of widgets. Customised display of X2 series offers direct access to the results of your work and other important information directly from the home screen.

Weighing Data Management

USB interface facilitates quick transfer and copying of any results of your work (measurements, reports, databases) to other balances. Managing the databases of balances may be also carried out over network thanks to E2R system also offering the possibility of remote control. Network management of the weighing data increases effectivity, productivity and safety of the important data to the maximum.

ALIBI Memory

The X2 series balances feature ALIBI memory that is a warranty for safety and automatic recording of your measurements. Options such as data preview, copying and archiving are available to users, as well. The used ALIBI memory allows to record up to 500 000 weighing records.

Technical specification:

	PS 200/2000.X2	PS 210.X2	PS 360.X2	PS 600.X2	PS 750.X2	PS 1000.X2
Verification	●	●	●	●	●	●
Max capacity	200 / 2000 g	210 g	360 g	600 g	750 g	1000 g
Minimum load	20 mg	20 mg	20 mg	20 mg	20 mg	20 mg
Readability	1 / 10 mg	1 mg	1 mg	1 mg	1 mg	1 mg
Tare range	-2000 g	-210 g	-360 g	-600 g	-750 g	-1000 g
Repeatability *	1 / 10 mg	1 mg	1 mg	1,5 mg	1,5 mg	1,5 mg
Linearity	±2 / ±20 mg	±2 mg	±2 mg	±3 mg	±3 mg	±3 mg
Pan size	128×128 mm					
Working temperature	+10 ÷ +40 °C					
Stabilization time	2 s / 1,5 s	2 s				
Sensitivity drift	2 ppm/°C in temperature +10 ÷ +40 °C					
Minimum weight (USP)	1 g					
Minimum weight (U = 1%, k = 2)	0,1 g					
Interface	2 × RS 232, USB-A, USB-B, Ethernet, Wireless Connection					
Power supply	12 ÷ 16 V DC / 350 mA					
Adjustment/calibration	internal (automatic)					
Display	5" colour capacitive touchscreen					
Net weight/Gross weight	3,5 / 5,5 kg	3,5 / 5,5 kg	3,5 / 5,5 kg	3,5 / 5,5 kg	3,5 / 5,5 kg	3,5 / 5,5 kg
Packaging size	470×380×336 mm					

Technical specification:

	PS 1200.X2	PS 2100.X2	PS 3500.X2	PS 4500.X2	PS 6000.X2	PS 6001.X2
Verification	●	●	●	●	●	●
Max capacity	1200 g	2100 g	3500 g	4500 g	6000 g	6000 g
Minimum load	500 mg	500 mg	500 mg	500 mg	500 mg	500 mg
Readability	10 mg	10 mg	10 mg	10 mg	10 mg	100 mg
Tare range	-1200 g	-2100 g	-3500 g	-4500 g	-6000 g	-6000 g
Repeatability *	10 mg	10 mg	10 mg	10 mg	15 mg	100 mg
Linearity	±20 mg	±20 mg	±20 mg	±20 mg	±30 mg	±100 mg
Pan size	195×195 mm					
Working temperature	+10 ÷ +40 °C					
Stabilization time	1,5 s					
Sensitivity drift	2 ppm/°C in temperature +10 ÷ +40 °C					
Minimum weight (USP)	10 g					
Minimum weight (U = 1%, k = 2)	1 g					
Interface	2 × RS 232, USB-A, USB-B, Ethernet, Wireless Connection					
Power supply	12 ÷ 16 V DC / 350 mA					
Adjustment/calibration	internal (automatic)					
Display	5" colour capacitive touchscreen					
Net weight/Gross weight	3,6 / 5,1 kg	3,6 / 5,1 kg	3,6 / 5,1 kg	3,6 / 5,1 kg	3,6 / 5,1 kg	4,8 / 6,3 kg
Packaging size	470×380×336 mm					

* Repeatability is expressed as a standard deviation from 10 weighing cycles.

Dimensions:

PS 200/2000.X2 - PS 1000.X2

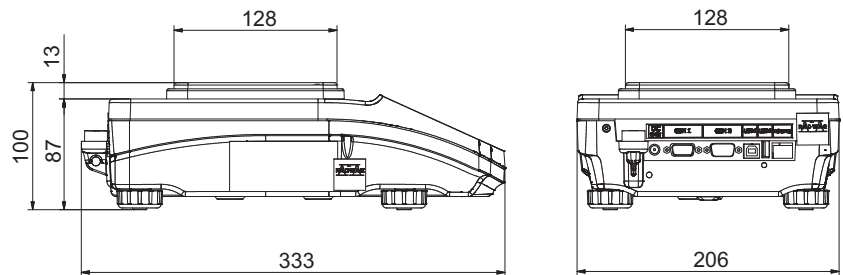

PS 1200.X2 - PS 6001.X2

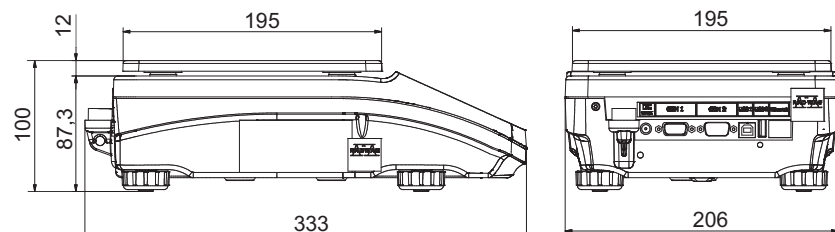

Technical specification:

	PS 6100.X2	PS 8100.X2	PS 10100.X2
Max capacity	6100 g	8100 g	10100 g
Minimum load	500 mg	500 mg	500 mg
Readability	10 mg	10 mg	10 mg
Tare range	-6100 g	-8100 g	-10100 g
Repeatability *	10 mg	12 mg	15 mg
Linearity	±30 mg	±30 mg	±30 mg
Pan size		195×195 mm	
Working temperature **		+10 ÷ +40 °C	
Stabilization time		1,5 s	
Sensitivity drift		2 ppm/°C in temperature +10 ÷ +40 °C	
Minimum weight (USP)		10 g	
Minimum weight (U = 1%, k = 2)		1 g	
Interface	2 × RS 232, USB-A, USB-B, Ethernet, Wireless Connection		
Power supply	12 ÷ 16 V DC / 350 mA		
Adjustment/calibration	internal (automatic)		
Display	5" colour capacitive touchscreen		
Net weight/Gross weight	5,6 / 7,1 kg	5,6 / 7,1 kg	5,6 / 7,1 kg
Packaging size	470×380×336 mm		

* Repeatability is expressed as a standard deviation from 10 weighing cycles.

** The balance retains parameters compliant with type approval certificate for temperature range +15° - +35° C

Dimensions:

PS 6100.X2 - PS 10100.X2

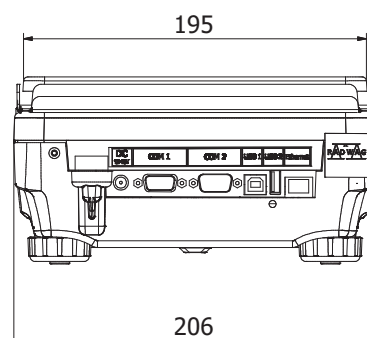
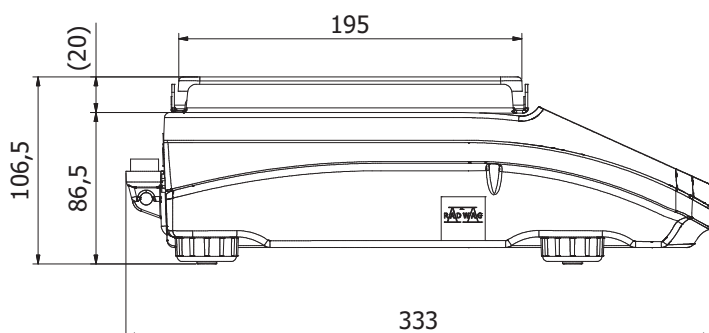

Accessories:

Antivibration table for laboratory balances	Bar code scanner USB HID
Antivibration table SAL/STONE	Power loop output AP2-1 (plastic housing)
Impact printer Epson	Additional LCD display "WD-6"
Printer USB PCL	Power adapter with battery and charger ZR-02
Density determination kit	Mass standard
Rack for under hook weighing	Draft shield (for balances featuring 128x128 weighing pan)
"Tare" or "Print" foot button	USB A- USB B cable (balance - computer, balance - PLC printer)
PC keyboard USB	Cable RS 232 (scale - computer) "P0108"
External USB memory (FAT files format)	Cable RS 232 (scale, Epson printer) "P0151"
Bar code scanner	"PW-WIN" computer software
	"RAD-KEY" computer software