

PRECISION BALANCES SERIES WTC



release date 02-03-2017



WTC balances are designed for fast and precise determination of mass in laboratory conditions.

They can be used in locations with no access to (240V) as they feature internal rechargeable battery.

Balances are equipped with: weighing pan made of stainless steel, RS 232, USB-A and USB-B connectors and backlit LCD ensuring clarity of the result.

- Parts counting
- Percent deviations
- Totalizing
- Plus/Minus Control
- Internal battery
- Peak hold

Technical specification:

	WTC 200	WTC 600.1	WTC 2000	WTC 3000
Maximal capacity	200 g	600 g	2000 g	3100 g
Minimal load	-	-	-	-
Readability [d]	0,001 g	0,01 g	0,01 g	0,1 g
Verification unit [e]	-	-	-	-
Tare range	-200 g	-600 g	-2000 g	-3100 g
Repeatability	0,002 g	0,01 g	0,01 g	0,1 g
Linearity	±0,004 g	±0,02 g	±0,03 g	±0,3 g
Stabilization time	2 s	2 s	2 s	2 s
OIML class	-	-	-	-
Working temperature	+15° +30° C			
IP rating	IP 43			
Power supply	100 ÷ 240 V AC 50 ÷ 60 Hz / 12 V DC + battery			
Adjustment	external			
Battery operating time	33 hours			
Pan size	Ø 100	128 × 128 mm	128 × 128 mm	128 × 128 mm
Display	LCD (backlit)			
Interface	RS 232, USB-A, USB-B	RS 232, USB-A, USB-B		
Net weight / Gross weight	1,2 kg / 1,7 kg	1,3 kg / 2 kg		
Packaging dimensions	33 × 22 × 14 cm			

Dimensions:

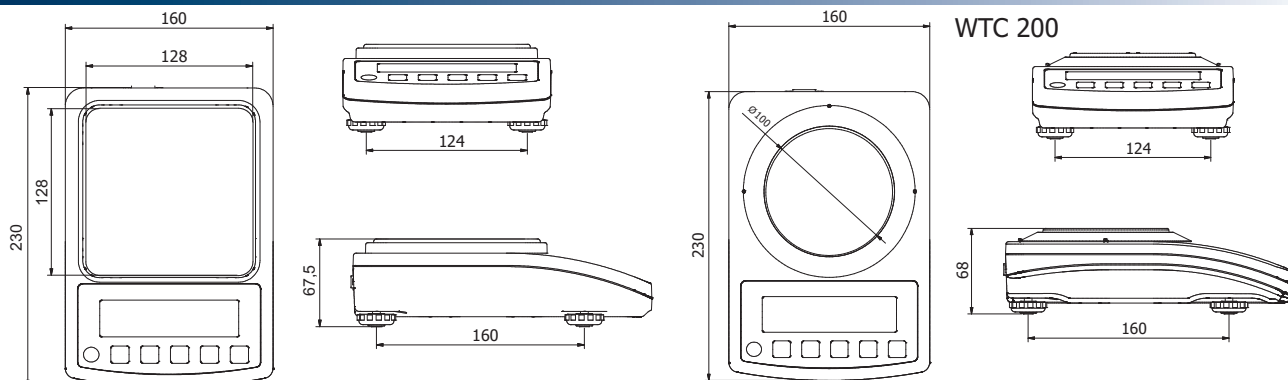

Additional equipment:

IMPACT "EPSON" PRINTER	RS 232/RS 485 CONVERTER
TABLE FOR SCALE	POWER LOOP AP-2
COMPUTER SOFTWARE: PW-WIN, RAD-KEY	